

# SPECIFICATIONS AND ORDERING INFORMATION

# E1 - SERIES

1 1/2" MAXIMUM DIAMETER 1.5 AMPS @ 28 VDC

The E1 Series offers a strong positive 30° index in a hill and valley design, and a small front housing. This series is superior where depth-behind-panel is critical.



## SPECIFICATIONS

### ELECTRICAL

**Current and Voltage Rating:** Make and break resistive load 1.5 amps @ 28 VDC; 0.25 amp @ 115 VAC.  
**Current Carrying Capacity:** 9 amps.  
**Dielectric Strength:** 1,000 VAC between current carrying parts and ground.  
**Contact Resistance:** Average initial 3.5 milliohms.  
**Insulation Resistance:** In excess of 750,000 megohms.

**Hardware:** Mounting nut and lockwasher are shipped assembled.

### MECHANICAL

**Materials and Finishes:** All parts utilize non-corrosive materials as standard.  
**Clips and Rotors:** Brass with silver plate as standard.  
**Insulation:** Glass epoxy.  
**Index:** Formed spring, hill and valley design.  
**Index Life:** 10,000 cycles minimum.  
**Index Torque:** Switches have lowest practical torque consistent with crisp detenting and smooth, reliable operation.  
**Index Angles:** Positive 30° standard.  
**Index Stops:** Fixed stops standard.  
**Stop Strength:** 10 in. lbs. minimum.

## STANDARD PART NUMBER

### GLASS EPOXY INSULATION

SWITCHES - 30° INDEXING - FIXED STOPS - SOLDER LUG TERMINALS

POLES	ACTIVE POSITIONS	POLES/ SECTION	NO. OF SECTIONS	SHORTING	NON-SHORTING	DETAIL
01	02	1	1	E1G0102S	E1G0102N	A
01	03	1	1	E1G0103S	E1G0103N	B
02	02	2	1	E1G0202S	E1G0202N	C
02	03	2	1	E1G0203S	E1G0203N	D

## DIMENSIONS

### STANDARD CONSTRUCTION

### E1G - GLASS EPOXY CONSTRUCTION

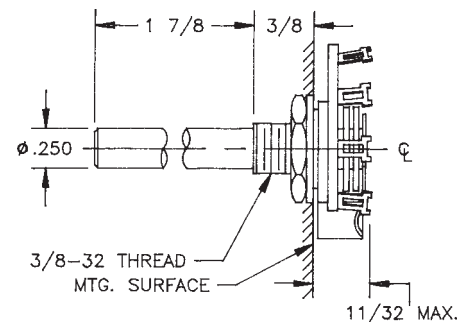

## DIMENSIONS

